

CAUTION : Read instructions thoroughly and completely prior to beginning installation.

Installation Instructions Separable Straight Connector - CENELEC interface type A



Only to be used on copper wire screened cable with extruded semi-conductive screen and conductors of copper or aluminium.

Check if the diameter over cable core insulation is in accordance with the cable reducer range as indicated in table below:

Cable reducer size (see marking inside cable reducer)	Dia. over core insulation (mm)	
	min	max
200CA-12	13.0	21.0
200CA-16	17.5	25.0
200CA-19	21.5	28.5

Contents :

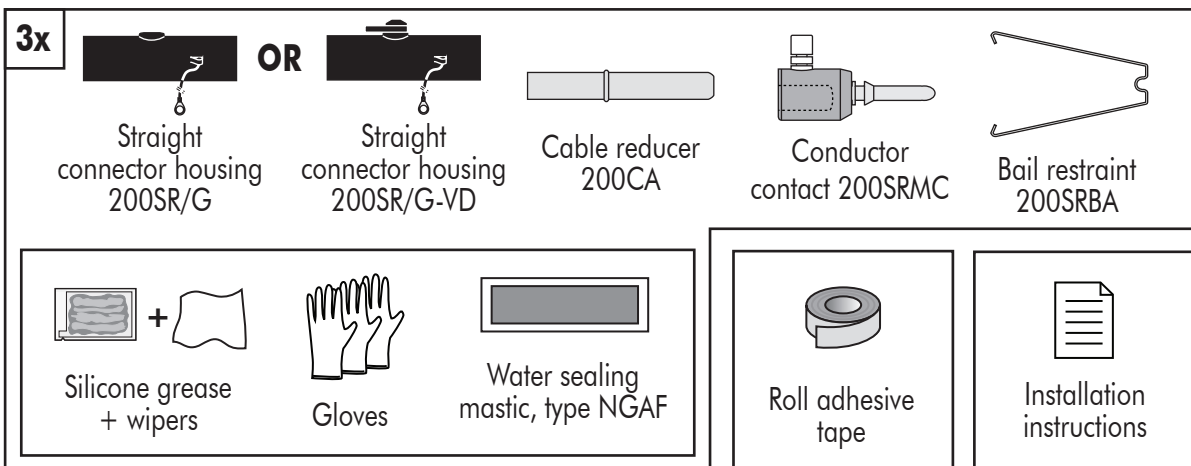

CABLE PREPARATION

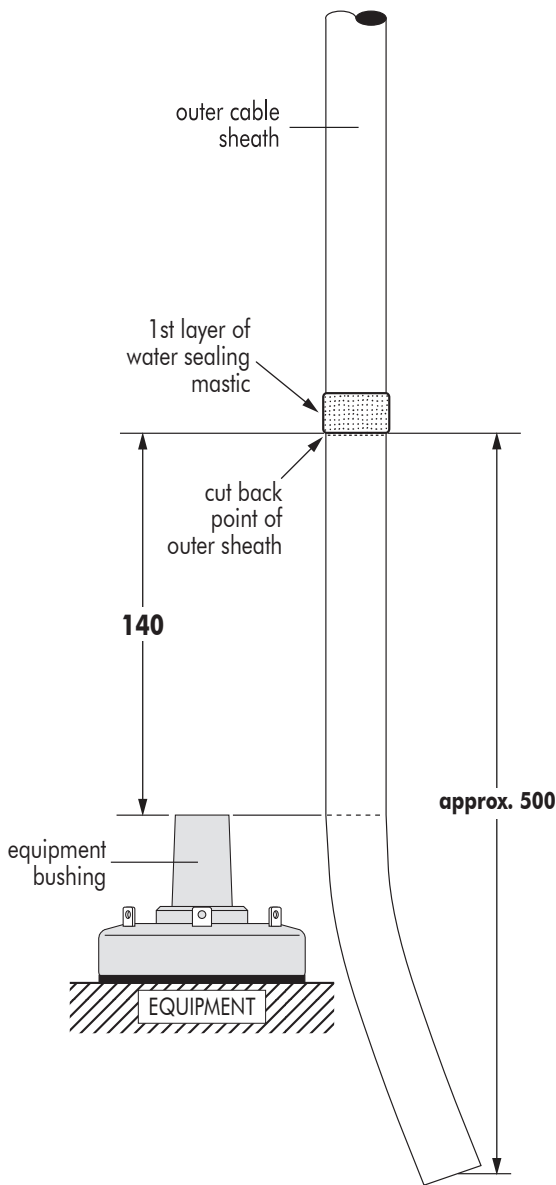

- 1 Train the cable into the approximate finished position next to the equipment bushing.
- 2 Mark the position of the face of the bushing on the cable.
- 3 Remove the outer sheath to a point **140** mm from the face of the bushing.
- 4 Wrap a first layer of water sealing mastic around the outer sheath, slightly stretched.

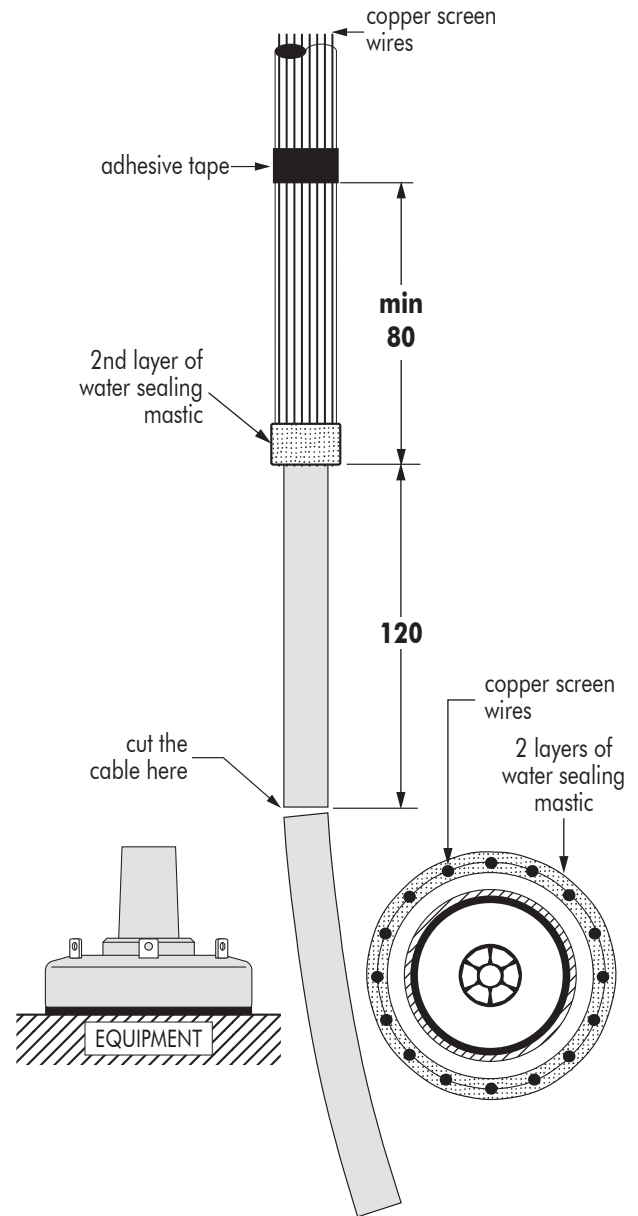

- 4 Bend the screen wires back over the outer sheath, pressing them into the mastic.
Note: screen wires should not touch or overlap each other to prevent water ingress.
- 5 Using adhesive tape, fix the screen wires at a distance of min **80** mm from the edge of the outer sheath.
- 6 Apply a second layer of water sealing mastic, slightly stretched.
- 7 Cut the cable to a point **120** mm from the outer sheath.

SEMI-CONDUCTIVE SCREEN REMOVAL

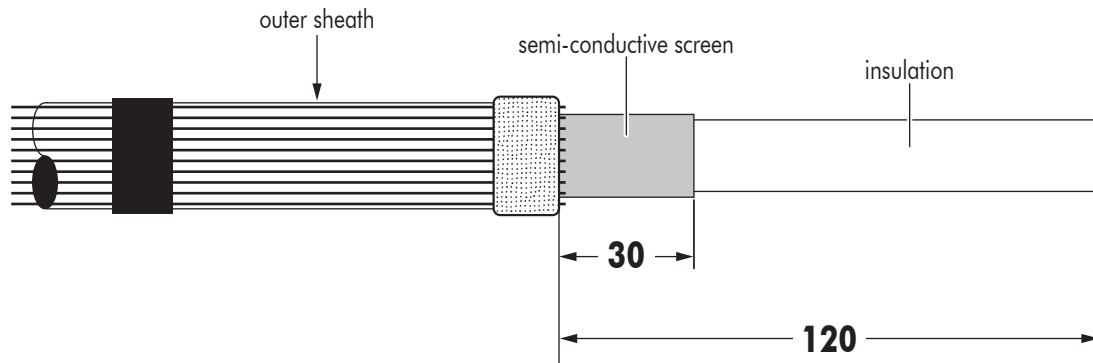

- 1 Check distance of **120** mm.
- 2 Remove the semi-conductive screen to a point **30** mm from the outer sheath.
For extruded easy strip semi-conductive screen:
 Cut squarely taking care not to cut the core insulation.
For bonded extruded semi-conductive screen:
 Use an appropriate pencilling tool. Make a smooth transition between core insulation and semi-conductive screen.

REMOVAL OF THE CORE INSULATION

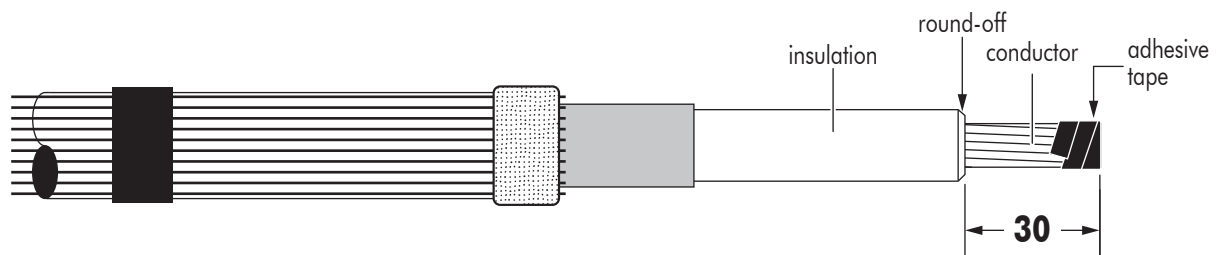

- 1 Remove the core insulation from the conductor for a distance of **30** mm.
- 2 Slightly round-off the edge of the core insulation. **Do not sharpen in cone-shape.**
- 3 **Thoroughly clean core insulation.** Always wipe towards the screen wires.
- 4 As a protection, wrap a few turns of adhesive tape around the conductor end.

INSTALLATION OF THE CABLE REDUCER

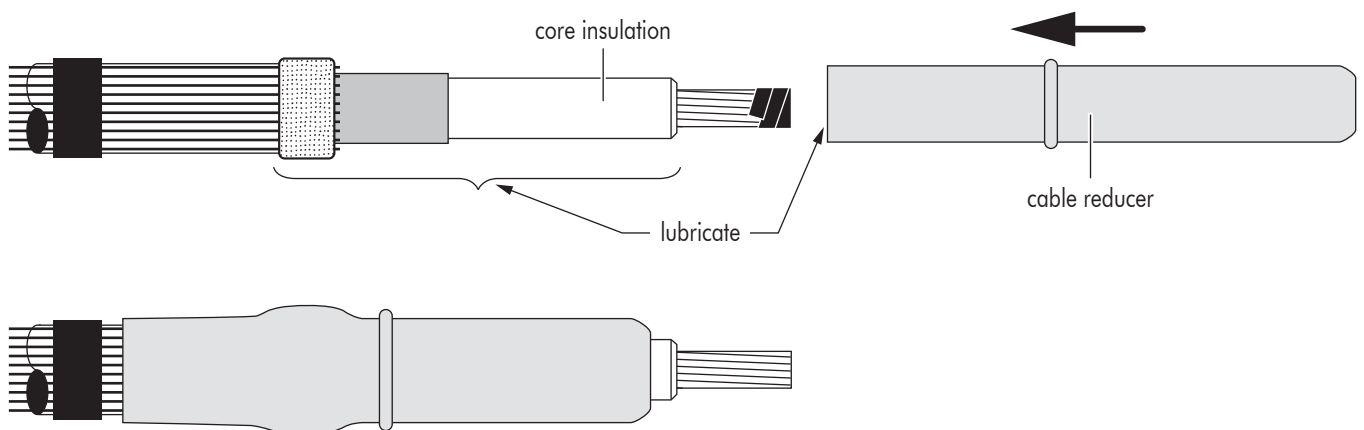

- 1 Lubricate* the indicated area : cable surface and inner surface of the reducer.
- 2 Slide the reducer down the cable.
- 3 Remove the protective adhesive tape from the conductor.

* USE ONLY THE SILICONE LUBRICANT SUPPLIED

TIGHTENING OF THE CONTACT

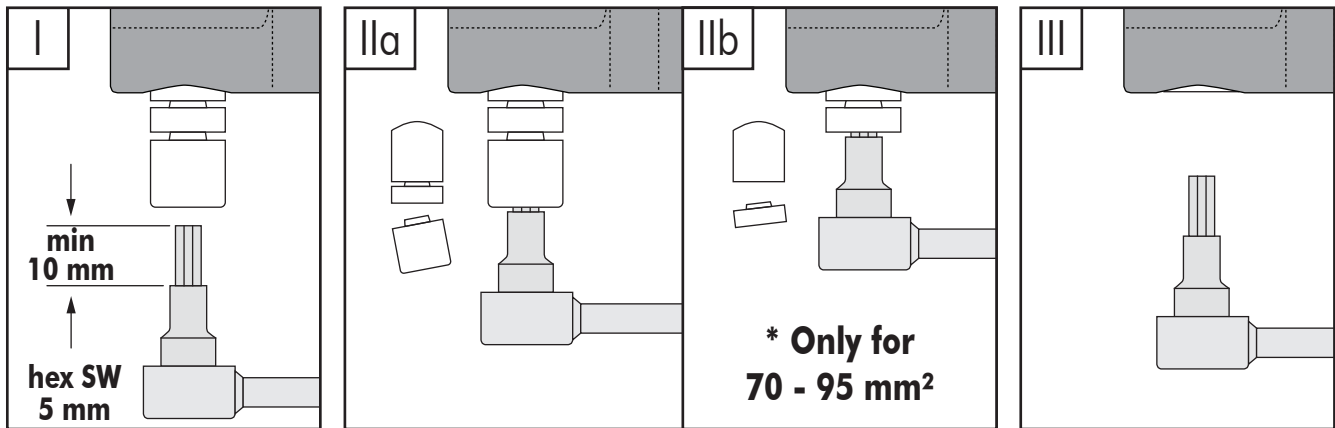
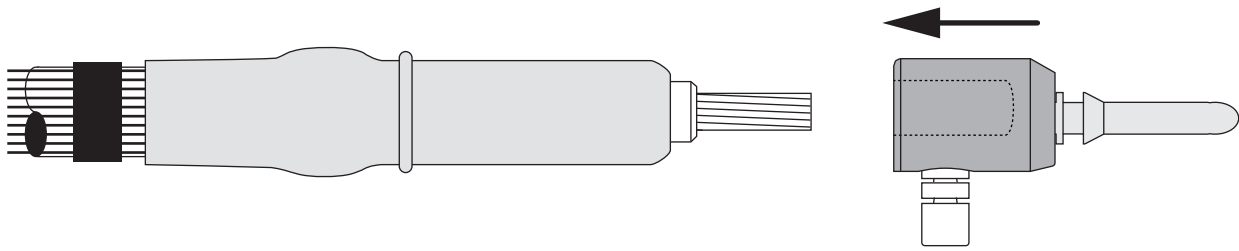

- 1** For aluminium conductors, wire brush the conductor to break up the oxide layer and insert into barrel immediately.
- 2** Tighten the contact until the bolt head shears off.
It is recommended to use the holding tool for ease of installation.
(*) For 70 - 95 mm², tighten again until the second level of the bolt head shears off.

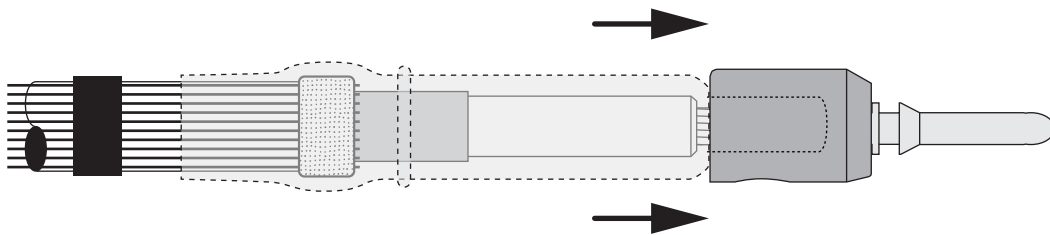

- 3** After tightening the contact, slide the cable reducer up until it butts against the contact.

CONNECTOR INSTALLATION ON THE CABLE

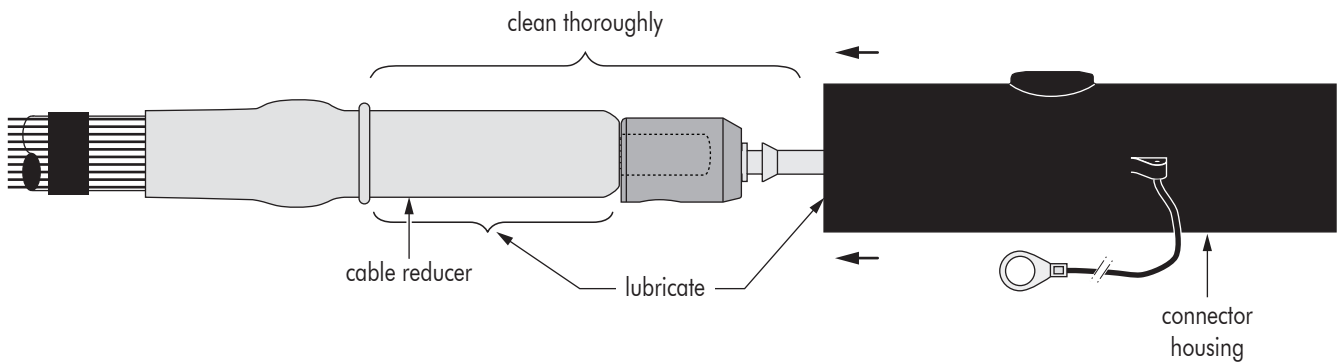

1 Thoroughly clean cable reducer and contact.

Always wipe towards the screen wires.

2 Lubricate* cable reducer and inside surface of the connector.

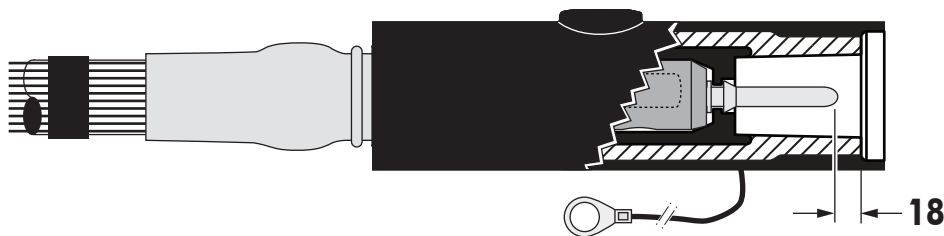

3 Hold the cable reducer with one hand, whilst sliding the connector housing on to the reducer, until the pin contact locks into the connector as shown. Check dimension of **18** mm.

CONNECTOR INSTALLATION ON THE BUSHING

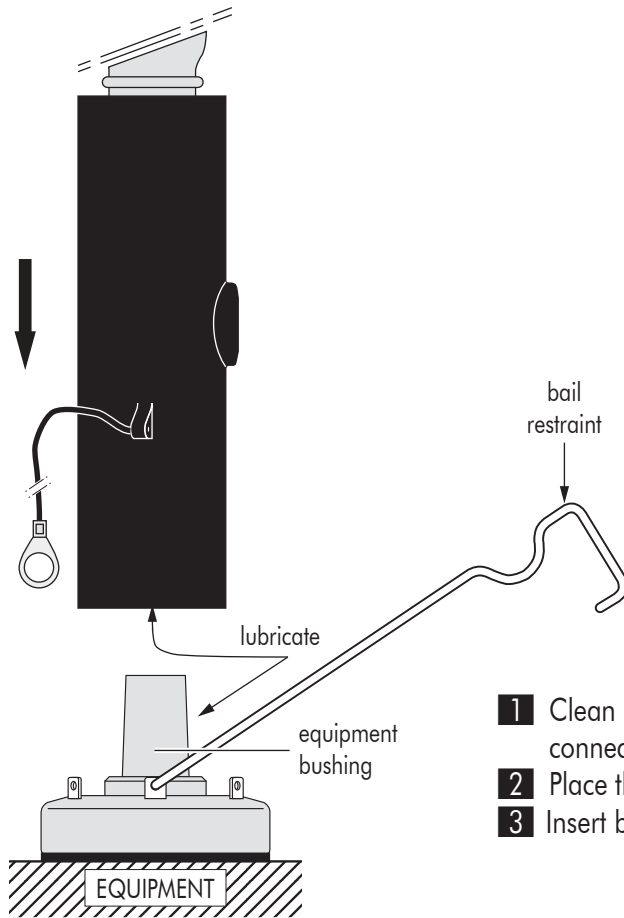

- 1** Clean and lubricate* both bushing interface and connector interface.
- 2** Place the connector firmly down on the bushing.
- 3** Insert bail into the bushing tabs.

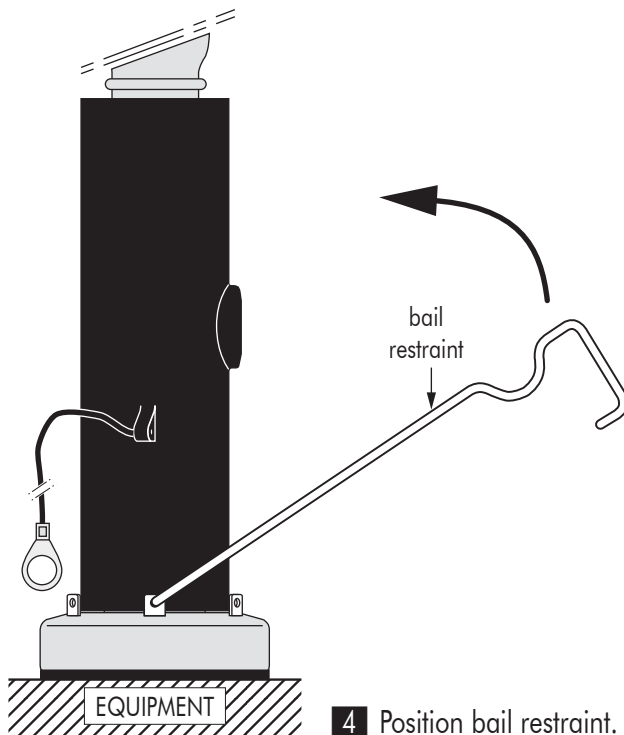

- 4** Position bail restraint.

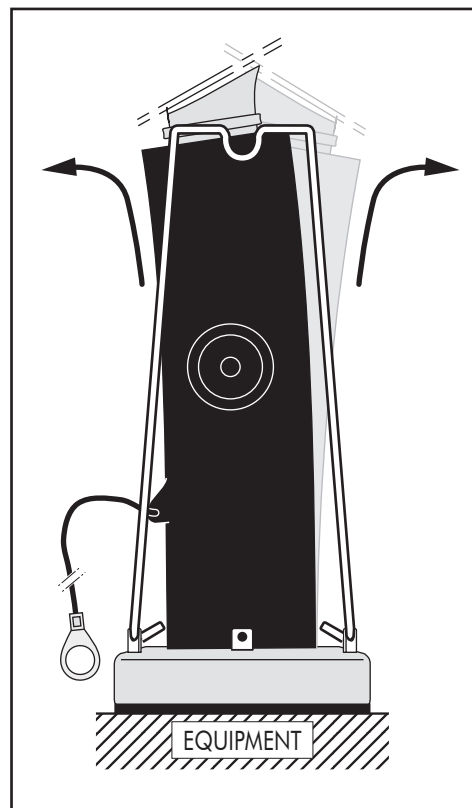

Installation hint :

if necessary, slightly bend the straight connector left-right to let the bail snap into position.

EARTHING AND CABLE CLAMPING

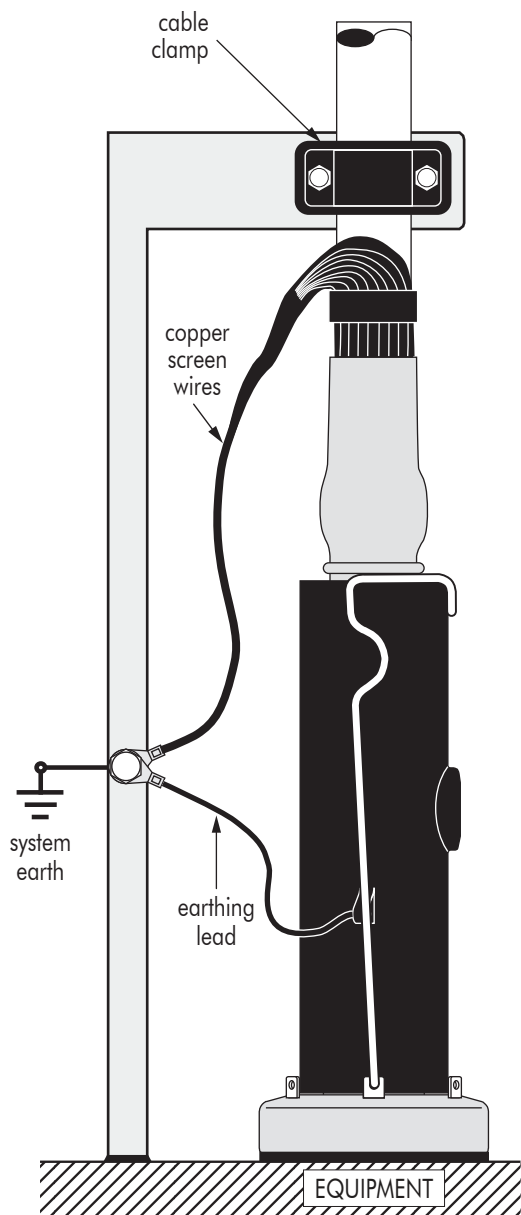

- 1 Twist screen wires to form a pig tail.
- 2 Connect earthing lead of the connector and the screen wires to the system earth.

NOTE :

A connector/bushing mated combination should not be allowed to carry the full weight of the cable. Therefore it is necessary to clamp the cable as close as possible to the connector.

IMPORTANT NOTES :

- Never disconnect the straight connector from energised equipment nor energise a disconnected straight connector without previously installing an appropriate mating part.
- Do not allow hydrocarbon oils or solvents to contaminate the E.P.D.M. rubber. In the event of contamination, wipe the surface clean with a dry cloth.